

Tennessee Comprehensive Assessment Program TCAP

Math Grade 5 | Practice Test



Please PRINT all information in the box.

Student Name: _____

Teacher Name: _____

School: _____

District: _____

All practice test items represent the appropriate grade level/content standards—however, the practice test may contain item types that no longer appear on the operational assessment.



TCAP Math Reference Sheet—Grade 5

1 yard = 3 feet
1 mile = 1,760 yards
1 mile = 5,280 feet
1 kilometer = 1,000 meters

1 pound = 16 ounces
1 ton = 2,000 pounds
1 kilogram = 1,000 grams

1 cup = 8 fluid ounces
1 pint = 2 cups
1 quart = 2 pints
1 gallon = 4 quarts
1 liter = 1,000 milliliters

**No test material
on this page**

Directions

This test has Subpart 1, Subpart 2, and Subpart 3. Each subpart contains various types of assessment questions. The following sample shows a type of question used.

You MAY NOT use a calculator in Subpart 1 of this test.

Sample A: Written response (fill in the blank)

A rectangular prism has the following dimensions.

- length 5 inches
- width 4 inches
- height 1 inch

What is the volume, in cubic inches, of the prism?

Enter your answer in the space provided.



Do not go on to the next page until told to do so.

**No test material
on this page**

**No test material
on this page**



1 What is $3\frac{1}{8} + \frac{3}{4}$?

Enter your answer in the space provided.

2 What is the value of 217×33 ?

Enter your answer in the space provided.



- 3** There are 4 ropes. Each one is $3\frac{1}{4}$ feet long.

Select the **three** expressions that would give the total length of all the ropes.

A. $3\frac{1}{4} + 3\frac{1}{4} + 3\frac{1}{4} + 3\frac{1}{4}$

B. $4 \times \frac{13}{4}$

C. $\frac{1}{4} \times 3\frac{1}{4}$

D. $\frac{12}{4} + \frac{12}{4} + \frac{12}{4} + \frac{12}{4}$

E. $\frac{13}{4} + \frac{13}{4} + \frac{13}{4} + \frac{13}{4}$

- 4** What is the value of the digit 7 when 2.7 is multiplied by 10^2 ?

M. 0.007

P. 0.07

R. 7

S. 70



5 What is the value of $384 \div 16$?

- A. 64
- B. 38
- C. 24
- D. 23

6 What is $1\frac{3}{8} - \frac{3}{4}$?

Enter your answer in the space provided.



- 7 The line plot shows the distance, in miles, that Jenny walked on 5 different days.

Distance Jenny Walks

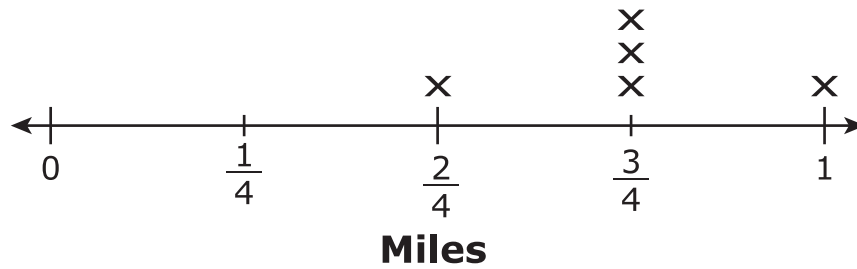

What is the total distance Jenny walked, in miles?

Enter your answer in the space provided.



- 8 What is the sum of $42.6 + 0.45 + 30.22$?

Enter your answer in the space provided.

- 9 Evaluate the expression.

$$64 \div (15 - 5 + 12 \div 2) + 9 \times 2 - 1$$

Enter your answer in the space provided.



- 10** Jose is packing cube-shaped blocks in the box shown.

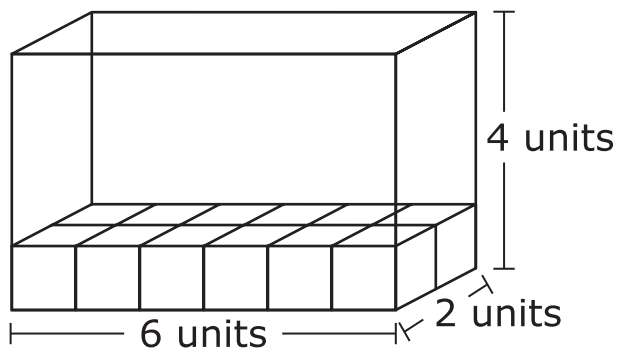

Which **two** expressions could be used to calculate the volume of the box, in cubic units?

- M.** 6×2
- P.** 12×2
- R.** 12×4
- S.** $6 + 2 + 4$
- T.** $6 \times 2 \times 4$



- 11** Select the **three** numbers with values **less than** “twelve and thirteen hundredths.”
- A.** twelve and one hundred forty-six thousandths
 - B.** twelve and twenty-five thousandths
 - C.** twelve and five tenths
 - D.** 12.103
 - E.** 12.072
- 12** What is 2.078 rounded to the hundredths place?
- M.** 2.10
 - P.** 2.08
 - R.** 2.07
 - S.** 2.00



**This is the end of Subpart 1 of the Math Practice Test.
Do not go on to the next page until told to do so.**

**No test material
on this page**

Directions

Subpart 2 of this test contains various types of assessment questions. The following sample shows a type of question used.

You MAY use a calculator in Subpart 2 of this test.

Sample B: Graphing

Draw a right triangle with one vertex at $(4, 2)$ on the following grid.

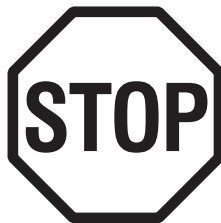
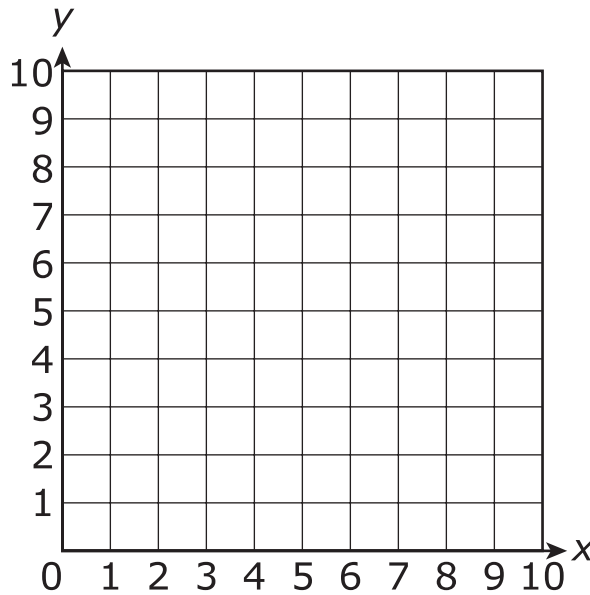

Do not go on to the next page until told to do so.

**No test material
on this page**



- 13** Carol has $8\frac{3}{4}$ yards of material. She needs to use $\frac{1}{3}$ of the material to make a dress. How many yards of material will she need to make the dress?

Enter your answer in the space provided.

- 14** The amounts of candy sold to seven customers are recorded on the line plot.

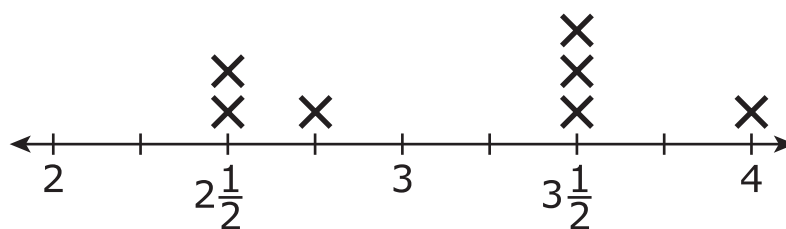

Candy Sold (in pounds)

What is the difference, in pounds, between the greatest amount and the least amount of candy sold?

- A.** $1\frac{1}{2}$
- B.** $1\frac{1}{4}$
- C.** 1
- D.** $\frac{3}{4}$



- 15** A rectangular container has a square base with an area of 25 square inches. The container has a height of 4 inches. What is the volume, in cubic inches, of the container?

Enter your answer in the space provided.

- 16** Sari had $\frac{3}{4}$ of a bag of pretzels. Her younger brother ate some, leaving her with $\frac{1}{8}$ of a bag.

What fraction of the bag did Sari's brother eat?

- M.** $\frac{4}{12}$
- P.** $\frac{2}{4}$
- R.** $\frac{5}{8}$
- S.** $\frac{7}{8}$



- 17** Suzan collected 560 milliliters of rainwater on Saturday. She collected 3.5 liters of rainwater on Sunday.

How many total milliliters of rainwater did Suzan collect on Saturday and Sunday?

- A.** 910
- B.** 4,060
- C.** 4,600
- D.** 9,100

- 18** What is the volume of this figure?

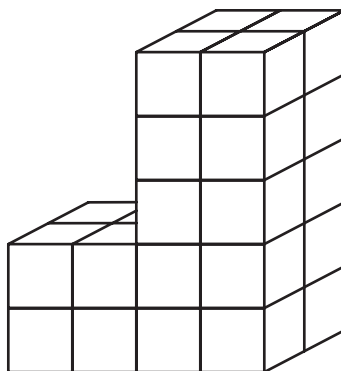

- M.** 12 cubic units
- P.** 16 cubic units
- R.** 28 cubic units
- S.** 40 cubic units



- 19** John is building a stage for a school play. The stage is $15\frac{1}{2}$ feet long and 20 feet wide. Select **all** options that represent the area of the stage, in square feet.

A. $\frac{31}{2} \times \frac{1}{20}$

B. $\frac{30}{2} \times 20$

C. $\frac{31}{2} \times 20$

D. 300

E. 310



**This is the end of Subpart 2 of the Math Practice Test.
Do not go on to the next page until told to do so.**

Directions

Subpart 3 of this test contains various types of assessment questions.

You MAY use a calculator in Subpart 3 of this test.



20 Which shape would **always** be considered a rhombus?

- A.** square
- B.** rectangle
- C.** quadrilateral
- D.** parallelogram

21 The first layer of a rectangular prism is packed with 15 unit cubes. There are no spaces or gaps between the cubes. The prism is 3 unit cubes tall.

Which expression represents the volume of the rectangular prism?

- M.** 15×3
- P.** $15 + 3$
- R.** $15 \times 3 \times 3$
- S.** $15 \times 15 \times 3$



- 22 Graph the point (3,7) on the following coordinate grid.

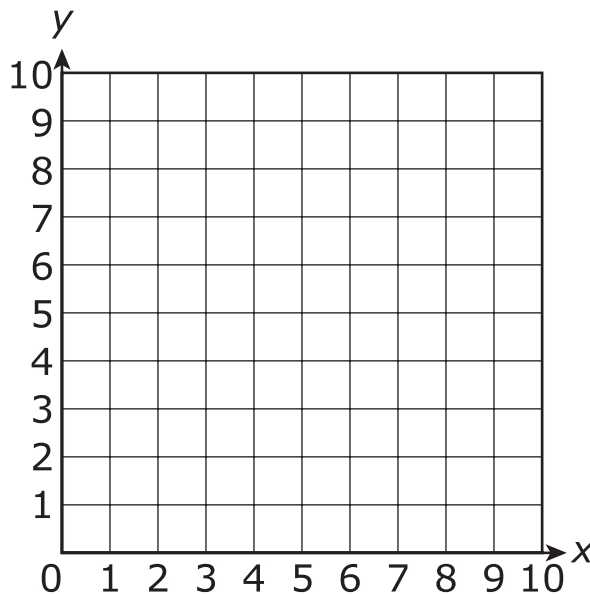

- 23 There are 5 bags of jelly beans. Each bag is $\frac{7}{8}$ full. Which expression can be used to represent the total amount of full bags of jelly beans?

- A. $7 \div (8 \times 5)$
- B. $(5 \times 7) \div 8$
- C. $8 \div (7 \times 5)$
- D. $6 \times (7 \div 5)$



24 Which expression is the correct numerical form of the following statement?

“the quotient of 8 and 4, times 7, plus the difference of 38 and 15”

M. $7 \times (4 \div 8) - (38 + 15)$

P. $(4 \times 7) \div 8 + (38 - 15)$

R. $(8 \times 4) \div 7 - (38 + 15)$

S. $(8 \div 4) \times 7 + (38 - 15)$

25 Laney put unit cubes together to make this rectangular prism.

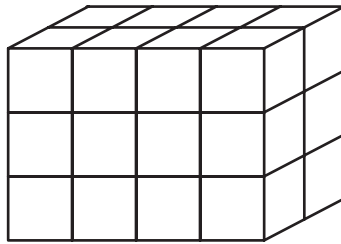

Which **two** expressions can be used to determine the volume, in cubic units, of Laney’s prism?

A. $4 + 3 + 2$

B. $6 + 8 + 12$

C. $8 + 8 + 8$

D. $4 \times 3 \times 2$

E. $6 \times 8 \times 12$



26 Mr. Brooks bought the amounts of clay listed for his class.

- 2.2 kilograms
- 1.5 kilograms
- 850 grams
- 700 grams

How many **grams** of clay did Mr. Brooks buy?

Enter your answer in the space provided.

27 Find the sum.

$$1\frac{1}{4} + \frac{5}{6}$$

Enter your answer in the space provided.



28 What is 473.69 rounded to the nearest whole number?

Enter your answer in the space provided.

29 A cup is filled with new, unsharpened pencils. The teacher sharpened $\frac{1}{4}$ of them. A student sharpened $\frac{2}{3}$ of them. What fraction of the pencils still needs to be sharpened?

M. $\frac{11}{12}$

P. $\frac{8}{12}$

R. $\frac{3}{12}$

S. $\frac{1}{12}$

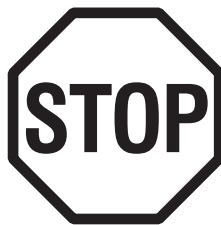

This is the end of the test.

**No test material
on this page**

Name: _____

Subpart 1 Practice Test Questions

1.

2.

3. A B C D E (select **three**)

4. M P R S

5. A B C D

6.

7.

8.

9.

10. M P R S T (select **two**)

11. A B C D E (select **three**)

12. M P R S

Subpart 2 Practice Test Questions

13.

14. A B C D

15.

16. M P R S

17. A B C D

18. M P R S

19. A B C D E (Select **all** that apply.)

Subpart 3 Practice Test Questions

20. A B C D

21. M P R S

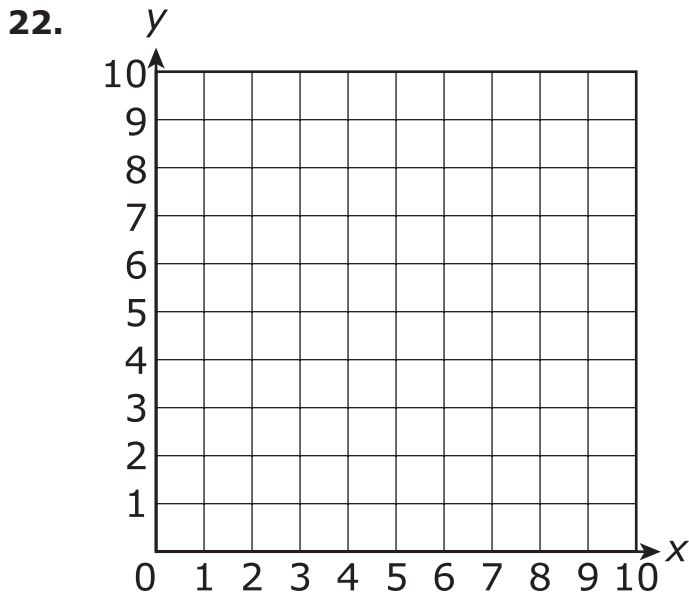

23. A B C D

24. M P R S

25. Ⓐ Ⓑ Ⓒ Ⓓ Ⓔ (select **two**)

26.

27.

28.

29. Ⓜ Ⓟ Ⓡ Ⓢ



**No test material
on this page**

Subpart 1 Practice Test Questions

1.

 $3\frac{7}{8}$ or equivalent

2.

7161

3. (select **three**)4. 5.

6.

 $\frac{5}{8}$ or equivalent

7.

 $3\frac{3}{4}$ or equivalent

8.

73.27

9.

21

10. (select **two**)11. (select **three**)12.

Subpart 2 Practice Test Questions

13.

14. B C D

15.

16. M P S

17. A C D

18. M P S

19. A B D (Select **all** that apply.)

Subpart 3 Practice Test Questions

20. B C D

21. P R S

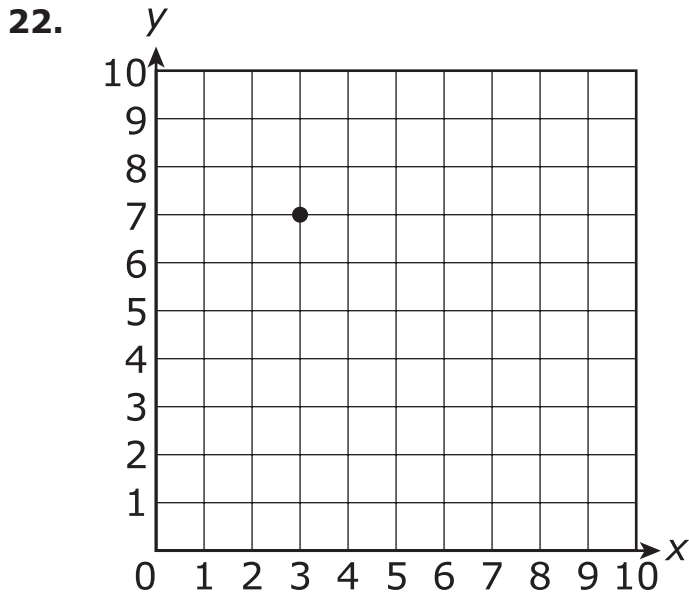

23. A C D

24. M P R

25. A B C D E (select **two**)

26.

27.

28.

29. M P R S

TNReady Practice Test Standards Alignment and Key – Grade 5

Subpart 1	Key	Standard
1	$3\frac{7}{8}$ or equivalent	5.NF.A.1
2	7161	5.NBT.B.5
3	A, B, E	5.NF.B.6
4	S	5.NBT.A.2
5	C	5.NBT.B.6
6	$\frac{5}{8}$ or equivalent	5.NF.A.1
7	$3\frac{3}{4}$ or equivalent	5.MD.B.2
8	73.27	5.NBT.B.7
9	21	5.OA.A.1
10	R and T	5.MD.C.5a
11	B, D, E	5.NBT.A.3
12	P	5.NBT.A.4
Subpart 2		
13	$2\frac{11}{12}$ or equivalent	5.NF.B.6
14	A	5.MD.B.2
15	100	5.MD.C.5b
16	R	5.NF.A.2
17	B	5.MD.A.1
18	R	5.MD.C.5c
19	C, E	5.NF.B.6
Subpart 3		
20	A	5.G.B.3
21	M	5.MD.C.5a
22	point plotted at (3, 7)	5.G.A.1
23	B	5.NF.B.4a
24	S	5.OA.A.2
25	C, D	5.MD.C.5
26	5250	5.MD.A.1
27	$\frac{25}{12}$ or equivalent	5.NF.A.1
28	474	5.NBT.A.4
29	S	5.NF.A.2

**No test material
on this page**

**No test material
on this page**

**No test material
on this page**

Tennessee Comprehensive
Assessment Program TCAP
Math
Grade 5 | Practice Test

